

Procedures for determination of light ship displacement and centre of gravity of Norwegian ships

Contents:

DETERMINATION OF LIGHT SHIP DISPLACEMENT AND CENTRES OF GRAVITY	3
1. INTRODUCTION	3
3. RESPONSIBILITIES	4
4. PREPARATIONS FOR THE LIGHTSHIP SURVEY.....	5
4.1 Notification of the Administration.....	5
4.2 General condition of the ship	5
4.3 Tanks	6
4.4 Draught measurements	6
4.5 Additional requirements for inclining tests:.....	7
4.6 Plans required	10
5. CONDUCTING AN INCLINING TEST	10
5.1 Requirements.....	10
5.2 Interpretation of plotted readings.....	12
5.3 Special considerations if a U-tube is used	13

DETERMINATION OF LIGHT SHIP DISPLACEMENT AND CENTRES OF GRAVITY

1. INTRODUCTION

According to *Norwegian regulations* concerning the construction of Norwegian passenger ships, cargo ships and barges, as well as for fishing vessels, the following principles for determination and approval of light ship displacement and position of the centre of gravity applies:

- The execution shall be based on procedures laid down by the Norwegian Maritime Authority (NMA), and the results shall be written in a prescribed format.
- The calculations of the light ship data shall be approved by the attending surveyor appointed by the NMA, before the ship goes into service.
- If the design of the ship is such that there is reason to assume that an inclining test carried out in accordance with normal procedures will not provide reliable light ship data, the NMA shall be contacted.

The purpose of the following guidelines is to ensure the accuracy of the light ship weight and centre of gravity, and constitutes the procedures referred to above. This document is based on Chapter 7 of IMO Resolution A.749(18), "Code on Intact Stability for All Types of ships Covered by IMO Instruments". Although that text was primarily written for large ships, these inclining test procedures are adaptable for ships with a length below 24 m if special precautions are taken to ensure the accuracy of the test. The Code also contains an annex with more detailed practical guidance for conducting an inclining test. Although not considered an integral part of these standard procedures, the NMA recommends that the contents of that annex are studied as additional guidance in connection with the planning of lightweight surveys and inclining tests.

While compliance with the procedures outlined herein will facilitate an expeditious and accurate lightweight survey and inclining test, it is recognized that alternative procedures or arrangements may be equally efficient, and may in some cases be necessary. However, to minimize risk of delay, all significant deviations from these guidelines must be submitted to the NMA for consideration in reasonable time prior to the execution. Such submissions must be accompanied by proposals for measures to be taken in order to achieve an equal level of accuracy.

For cargo ships, except offshore vessels, with a gross tonnage of 500 or more and which are registered in the Norwegian International Ship Register (NIS) the ship's classification society is permanently appointed to act on behalf of the NMA. For these ships deviations from these guidelines shall be forwarded to the classification society for consideration. The classification societies may require documentation in accordance with their own procedures.

As an alternative to these guidelines, Chapter 8 in «The International Code on Intact Stability, 2008» resolution MSC.267(85) may be used if followed in their entirety.

2. DEFINITIONS

Administration: The Norwegian Maritime Authority.

Approved: Approved by the NMA or whoever is authorised by the Authority ¹.

Inclining test: Determining the ship's vertical centre of gravity (VCG) in its current condition, normally by moving a series of known weights in the transverse direction, and then measuring the resulting change in the equilibrium heel angle of the ship.

Light ship condition: A ship complete in all respects, but without consumables, stores, cargo, crew and effects, and without any liquids on board except that machinery and system fluids, such as lubricants and hydraulics, are at their normal operating levels.

Lightweight survey: Recording the ship's floating condition and the mass, longitudinal, transverse and vertical location of each item which should be added, deducted or relocated on the ship in its current condition so that the observed condition of the ship can be adjusted to the light ship's displacement and the location of the centre of gravity. Determination of the transverse location (TCG) of the centre of gravity may also be required for other ships which are asymmetrical about the centreline or whose internal arrangement or outfitting is such that an inherent list may develop from off-centre weight.

Surveyor: Norwegian Maritime Authority (NMA) surveyor or other person appointed by and acting on behalf of the Norwegian Maritime Authority (NMA)

3. RESPONSIBILITIES

According to *Norwegian regulations*, the responsibility for initiating lightweight surveys and inclining tests rests with the yard for ships being built or modified in Norway, and with the owners if the ship is abroad.

A qualified person shall be in charge of making preparations, conducting the lightweight survey and inclining test, recording the data and calculating the results. This person may be a representative of the yard or the owners or a naval architect acting on their behalf. The responsibilities of this person are:

- Ascertaining that all necessary preparations have been made prior to the arrival of the attending surveyor.
- Administrate and coordinate the execution of the lightweight survey and inclining test.
- Gather complete results from all measurements as soon as these are available.
- Prepare results as expediently as possible in order to expose mistakes and inaccuracies at an early stage.
- Submit the final lightweight survey or inclining test report to the surveyor for approval in reasonable time before the planned departure of the ship.

The surveyor present shall:

- Attend the survey and note all information relevant for the approval of the final report
- Approve the report, if the conduct and the results are acceptable. The surveyor may reserve the right to present the report to the Administration for further evaluation if in doubt.
- Submit to the Administration a copy of the approved report together with a copy of the letter of approval.

In the case of a surveyor appointed on behalf of the NMA (excluding cargo ships with a gross tonnage of 500 or more registered in the Norwegian International Ship Register (NIS)), the surveyor shall:

- Verify that the contents of the report coincides with his own notes and that these procedures were adhered to
- Submit the report in triplicate to the NMA for approval

¹ For cargo ships, except offshore vessels, with a gross tonnage of 500 or more and which are registered in the Norwegian International Ship Register (NIS) the recognized classification societies have been granted a general authorization to act on behalf of the NMA.

4. PREPARATIONS FOR THE LIGHTSHIP SURVEY

4.1 Notification of the Administration

An Administration representative must be present to witness the lightweight survey and the results shall be submitted to the attending surveyor for approval.

Written notification of the survey should be sent to the Administration in due time before execution. For ships registered in the Norwegian ordinary ship register (NOR) notification shall be forwarded by the yard to the local NMA station in the case of ships being built in Norway and by the owners to the NMA head office for ships being built abroad.

For cargo ships with a gross tonnage of 500 or more and which are registered in the Norwegian International Ship Register (NIS) notification shall be forwarded to the classification society in accordance with the procedures laid down by the society.

Details of notification

Written notification should provide the following information:

- identification of the ship by name, callsign and/or shipyard hull number;
- date, time, and location of the survey;
- inclining weight data, if an inclining test is to be performed :
 - type of weights;
 - amount (number of units and weight of each);
 - certification of mass;
 - method of handling (i.e. sliding rail or crane);
- mass and location of righting- and/or trimming weights
- anticipated maximum angle of heel to each side;
- approximate location and length of pendulums
- If a substitution of a pendulum with an inclinometer or other device is desired, details on such solutions.
- approximate trim;
- condition of tanks;
- estimated weights to deduct, to complete, and to relocate in order to place the ship in its true lightship condition;
- description of computer software to be used to aid in calculations during the survey;
- name and phone number of the person responsible for conducting the survey.

4.2 General condition of the ship

The ship should be as complete as possible at the time of the lightweight survey, but some flexibility will be acceptable in order to minimize the disruption in the ship's delivery date or its operational commitments.

The amount and type of work left to be completed (weights to be added) affect the accuracy of the lightship characteristics, so good judgement should be used. If the weight or centre of gravity of an item to be added cannot be determined with confidence, the uncertainties will be reduced if the item is taken on board prior to the survey.

Temporary material, toolboxes, staging, sand, debris, etc., on board should be reduced to an absolute minimum before the lightweight survey.

All bilge water must be removed.

System piping and system tanks should be filled to their normal operating levels.

All spaces shall be available for inspection. Manholes leading to void spaces and tanks assumed empty shall be opened. These spaces must be ventilated and gas free to ensure that inspection can take place without danger. An explosion proof-testing device to check for sufficient oxygen and absence of lethal gases must be available.

Decks should be free of water. Water trapped on deck during an inclining test may shift and pocket in a fashion similar to liquids in a tank. Any rain, snow or ice accumulated on the ship should be removed prior to the lightweight survey.

A deviation from design trim of up to 1% of L is normally acceptable when using hydrostatic data calculated at design trim. Otherwise, the hydrostatic data should be calculated for the actual trim. Caution should be exercised when applying this "1 per cent rule of thumb" to ensure that excessive error, as would result from a significant change in the waterplane area due to heel, is not introduced into the stability calculations.

The water specific gravity should be accurately recorded.

4.3 Tanks

The anticipated liquid loading for a lightweight survey must be included in the planning for the survey. Preferably, tanks should be empty and clean, or completely full. *The number of filled-up tanks should be reduced as far as practical. When a lightweight survey has been accepted as replacement for an inclining test on new-buildings, the limits of tank contents as given in 4.5 below apply.*

Filled-up tanks shall not contain air pockets caused by trim or insufficient ventilation. Less than 100% full tanks (for example 98% as often used for loading conditions) are not acceptable. Before tanks are sounded, the ship should be heeled to both sides and if necessary trimmed, to avoid air pockets.

A list of the planned contents of each tank during the lightweight survey shall be submitted to the surveyor prior to the execution. This list shall also provide satisfactory information regarding the procedures for verifying the tanks' contents and their centres of gravity.

If the total tank contents exceed 20 % of the ship's displacement, the specific gravity of these contents must be verified by measurement.

Connections, including manifolds between tanks containing liquid shall be closed prior to the survey, and their controls secured in order to avoid unintended operation.

Notwithstanding these limitations it must be assured that the tank contents are sufficient to obtain adequate stability.

4.4 Draught measurements

Prior to the survey, the depth of water should be measured and recorded in as many locations as are necessary to ensure that the ship will not contact the bottom.

Draughts and freeboard shall be measured prior to the survey and in the case of an inclining test immediately before the weight movements. Check measurements should be taken after the survey to verify that there have not been any changes in draught and trim during the survey or inclining test.

Whenever possible, a dinghy should be available for the draught measurements. To avoid the effects of surge the draught readings may be taken with the help of a transparent plastic tube, throttled in the submerged end.

As a minimum draughts shall be measured at the fore and aft draught marks in addition to measuring the freeboard amidships at both sides. For large ships, or whenever a hogging or sagging condition may be expected, additional freeboard readings should be taken approximately halfway between amidships and the fore and aft draught marks.

If correct application of the draught marks has not been previously verified, additional freeboard readings should be taken, preferably at the draught marks if the hull shape permits.

In case of trim the longitudinal position of all readings must be noted in order to correct the values relative to the reference planes used in the ship's hydrostatic calculations. The longitudinal position of freeboard readings must always be carefully verified for ships with sheer.

If the ship has substantial trim all vertical readings may need correction with respect to the trim angle in order to coincide with the definition of draught for trimmed waterlines in the hydrostatic calculations.

If freeboards are not measured from the deck corner the vertical reference must be checked and noted.

4.5 Additional requirements for inclining tests:

Movable items

Excess crew or personnel not directly involved in an inclining test should not be on board the ship during the test.

All items, which may swing or shift, must be secured. Cranes, derricks, forklifts etc. shall be stowed and secured in their seagoing position.

Hatch covers etc. not needed open during the test shall be fixed in their seagoing position.

Tanks

The number of slack tanks should be kept to an absolute minimum. The viscosity of the fluid, the depth of the fluid and the shape of the tank should be such that the free surface effect can be accurately determined. Normally, just one or two of the following kinds will be accepted partly filled:

- Freshwater tank
- Fuel oil tank
- Fuel oil service tank

In order to obtain reliable free surface corrections slack tanks, if any, should be filled within these limits:

- Deep tanks : 20% - 80% full
- Double bottom tanks : 40% - 60% full

Tanks not intended to contain liquid shall be completely empty.

The number of filled-up tanks shall be reduced to the minimum that is necessary to maintain sufficient stability during the test.

Moorings

The ship should be moored in a quiet, sheltered area free from extraneous forces such as propeller wash from passing vessels or sudden discharges from shore side pumps. The tide conditions and the trim of the ship during the test should be considered. The ship should be moored in a manner to allow unrestricted heeling. The access ramps should be removed. Power lines, hoses, etc., connected to shore should be at a minimum, and kept slack at all times.

The ship should be as upright as possible and have sufficient draught so that any abrupt changes in the waterplane will be avoided, as the ship is inclined from side to side. With inclining weights in the initial position, up to one-half degree of list is acceptable.

Weights

The total weight used should preferably be sufficient to provide a minimum inclination of 2 degrees and a maximum of 4 degrees of heel to each side. However, a minimum inclination of 1.5 degrees to each side may be accepted for large ships such as tankers and bulk carriers.

Test weights should be compact and of such a configuration that the VCG (vertical centre of gravity) of the weights can be accurately determined. Each weight should be marked with an identification number and its mass. If reliable information on the weights cannot be presented to the surveyor, re-certification of the test weights should be carried out prior to the incline.

Inclining weights made of porous material which may absorb water must always be weighed prior to the test, and their use should only be accepted if the conditions are such that no further absorption may occur.

A crane of sufficient capacity and reach, or some other means, should be available during the inclining test to shift weights on the deck in an expeditious and safe manner. Using the ship's own cranes or derricks is normally not acceptable.

Water ballast is generally not acceptable as inclining weights. However, for large ships, water ballast transfer between tanks of a right-sided shape may be permitted, subject to prior consent by the Administration, and only when it is absolutely impractical to incline using solid weights. In such cases accurate sounding tables are of vital importance. The water specific gravity in such tanks must be accurately recorded, and ballast line branches not necessary for the conduct should be blind-flanged.

Pendulums

A minimum of two pendulums should be used to allow identification of bad readings at any one pendulum station. They should each be located in an area protected from the wind.

The pendulums should be long enough to give a measured deflection, to each side of upright, of at least 15 cm. To ensure that recordings from individual instruments are kept separate, it is suggested that the pendulums be physically located as far apart as practical.

The use of an inclinometer or U-tube may be considered in each separate case. Inclinometers or other measuring devices may, however, only be used in conjunction with at least one pendulum.

Efficient two-way communications should be provided between a central control and the weight handlers and between central control and each pendulum station. One person at the central control station should have complete control over all personnel involved in the test.

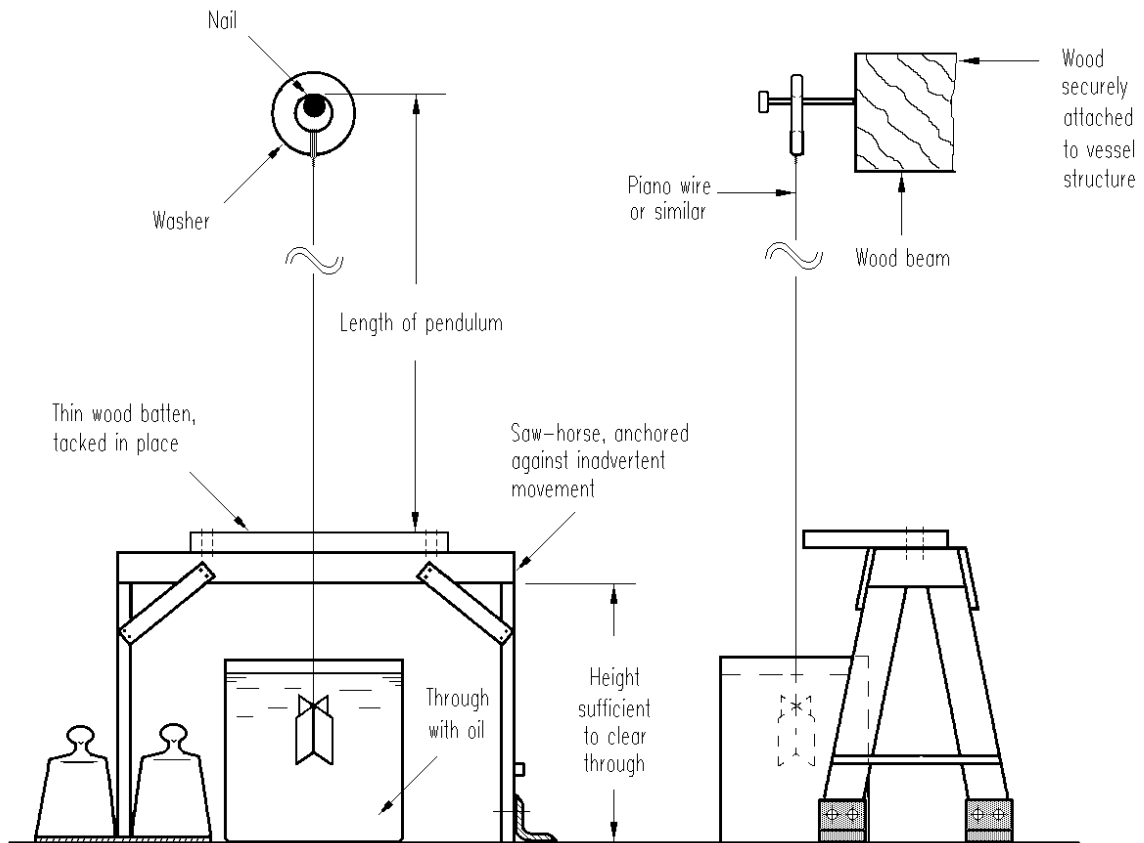

Fig. 1 Recommended set-up of pendulums

U-tubes

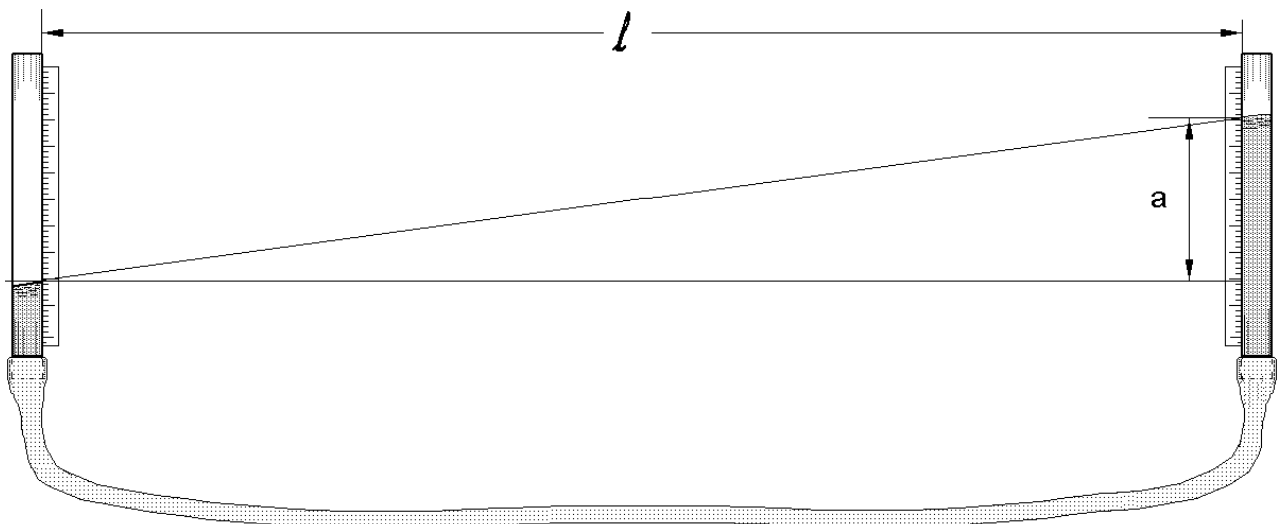

Fig. 2 Use of U-tube

Where a U-tube is used as a substitute for a pendulum the following must be complied with:

- The vertical ends of the device should be securely positioned as far outboard as possible. In any case shall the horizontal distance between the ends be sufficient to obtain a level difference of at least 15 cm between the upright and the maximum inclination to each side.

- It must be assured that the vertical ends are long enough to ensure that at maximum inclinations the water level will neither overflow nor disappear from the vertical ends.
- Fixed arrangements must be made for recording all readings at both ends.
- Clear plastic tube or hose must be used throughout in order to check for air pockets.

A small amount of ink or dye may be added to the water in the device for improved visibility.

Inclinometers

A copy of a calibration certificate from an institution acceptable to the Administration must be delivered to the surveyor prior to the test. As an additional confirmation, the inclinations obtained from the device must coincide with those from a pendulum.

The accuracy of the instrument should be in the order of +/- 0.01 degrees.

4.6 Plans required

The person in charge of the inclining test should have available a copy of the following plans at the time of the inclining test:

- lines plan;
- curves of form (hydrostatic curves) or hydrostatic data;
- general arrangement plan of decks, holds, inner bottoms, etc.;
- capacity plan showing capacities and vertical and longitudinal centres of gravity of cargo spaces, tanks, etc.;
- tank sounding tables;
- draught mark locations;
- docking drawing with keel profile and draught mark corrections (if available).

5. CONDUCTING AN INCLINING TEST

5.1 Requirements

The standard test employs eight distinct weight movements where movement no. 8 shall be a recheck of the zero point. The tangent to the accumulated pendulum deflection and the accumulated inclining moment shall be plotted in a diagram after each movement. The weight movements shall be such as to obtain distinct intermediate values between the zero point and the maximum deflections to each side in order to demonstrate linearity.

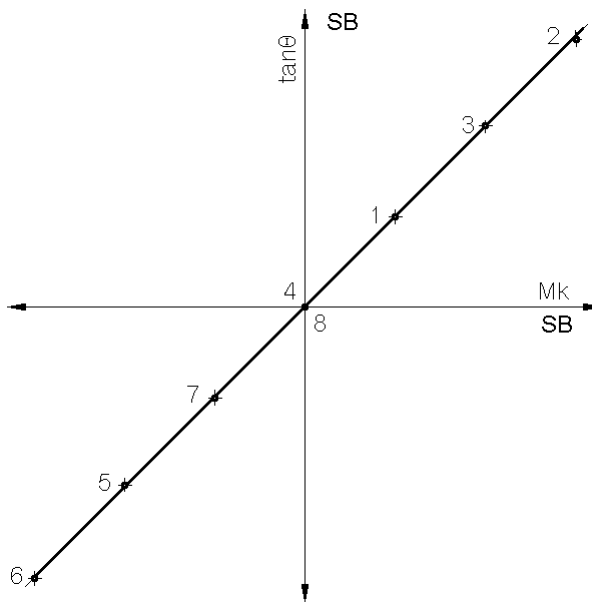

Fig. 3 Recommended sequence

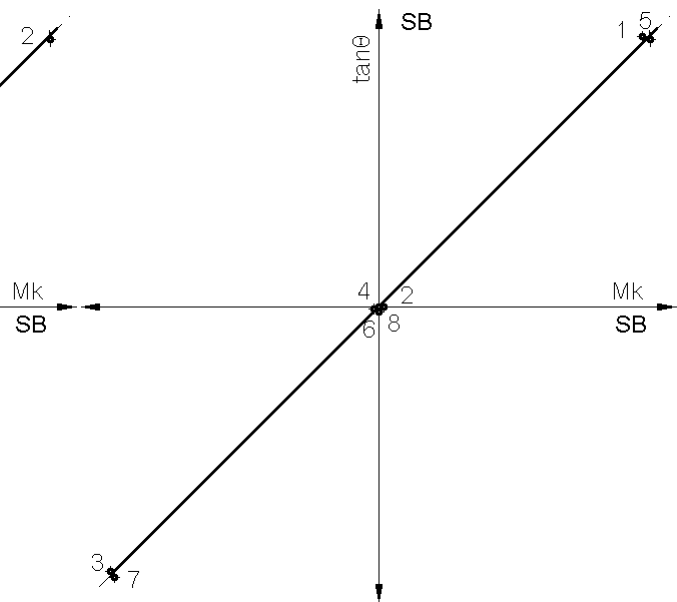

Fig. 4 Unacceptable distribution of points

The inclining test will not be complete until 8 acceptable plotted points have been achieved. If a reasonably straight-line plot is not obtained, those weight movements that did not yield acceptable plotted points should be repeated or the error source should be identified and corrected.

Disregarding plots and determining the ship's metacentric height by calculation alone (such as mean value of single values or "the least square method") is unacceptable, as errors and deviations may become hidden in the results.

Unfavourable weather and sea conditions may lead to an unacceptable degree of accuracy caused by for instance difficulties obtaining accurate draught and freeboard measurements, irregular pendulum readings and variable external moments. If the ambient conditions are such that there is reason to believe that accurate results cannot be obtained, the test shall be postponed if it is not possible to move the ship to a better location. Failure to achieve a straight line plot under such conditions should be taken as an indication that satisfactory results may not be possible.

It is required that inclination measurements are taken at least at 2 independent stations. If the plots from these stations do not coincide, the reason must be found, corrected and the test repeated or postponed as appropriate. If more than 2 stations are used, the results will be acceptable if 2 of those stations coincide.

A copy of the inclining data should be forwarded to the Administration along with the calculated results of the inclining test in an acceptable report format. Unless otherwise agreed, the NMA standard form "Report on inclining test and lightship survey" (Report 79) shall be used.

All calculations performed during the inclining test and in preparation of an inclining test report may be carried out by a suitable computer program. Output generated by such a program may be used for presentation of all or partial data and calculations included in the test report if it is clear, concise, well documented, and generally consistent in form and content with Administration requirements.

5.2 Interpretation of plotted readings

Shown in the following figures are some examples on failure to achieve correct plots, including probable causes and suggested measures to be taken.

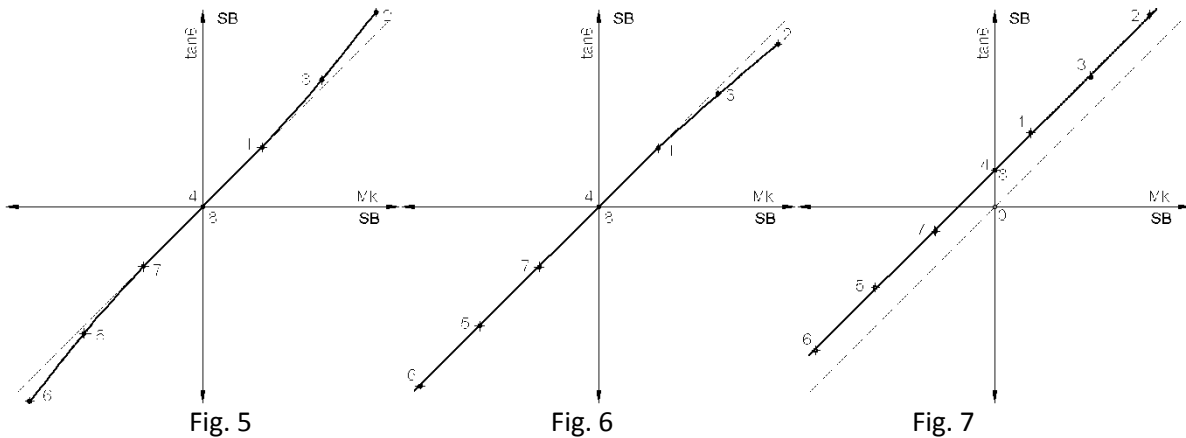

Fig. 5: Excessive free liquids. Re-check all tanks, voids and the tank top. Pump out or top up as necessary. Re-do all weight movements and re-check freeboard and draught readings.

Fig. 6: Ship touching bottom or pier, alternatively restrained by mooring lines. Take water soundings and check lines. Re-do weight movements 2 and 3.

Fig. 7: Steady wind from port side came up after initial zero point taken. This plot is acceptable.

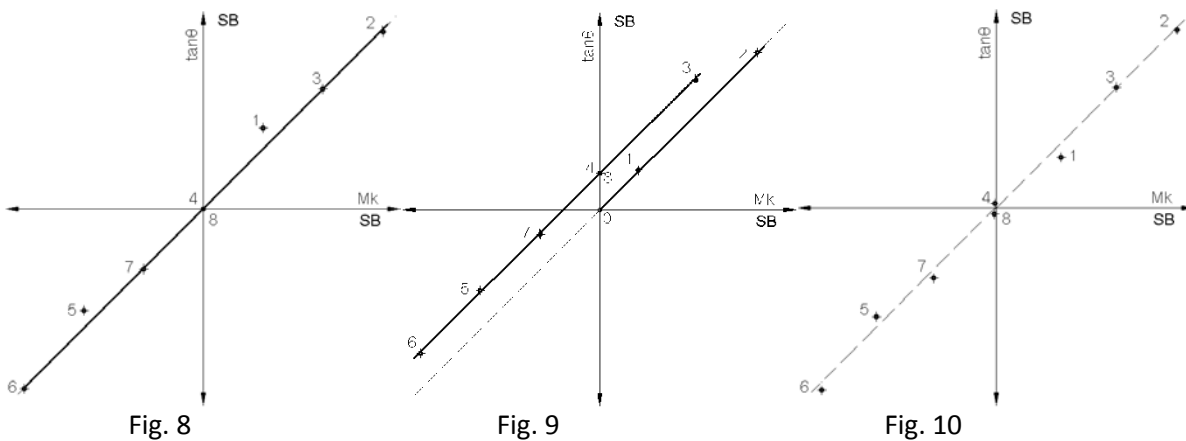

Fig.8: Gusty wind from port side. Re-do movements 1 and 5

Fig. 9: On one pendulum only: Measurement scaffolding or pendulum anchoring-point shifted between movements 2 and 3. Use data from the other pendulum(s) if a straight line was obtained there and the slopes of all lines coincide. On both pendulums: Possibly wind as on Fig. 7.

Fig. 10: Random variances: If the deviations cannot be related to specific causes, add extra movements to both sides until improved significance is obtained. The slope for all pendulums must coincide.

5.3 Special considerations if a U-tube is used

The device shall be thoroughly checked for air pockets immediately prior to the test.

The water levels in both ends shall be recorded for all movements, and the differences compared to ensure that no water has leaked from the device. Since, as opposed to a pendulum, U-tubes must be read at two sites for each movement extra care is necessary in order to maintain a constant heeling moment when the personnel is moving about.

If a valve is added to the device to choke the flow in order to dampen the effect of oscillation, sufficient time must be allowed for equalization before each reading.
